

TEHNICAL DATA SHEET

TPU FORCE (CARBON AND GLASS FIBER)

Date of issue: 09.10.2013

Date of update: 16.04.2024

Product description:

TPU FORCE reinforced with Glass and Carbon Fibers is a composite filament that merges the flexible properties of TPU 55D with the rigidity of glass and carbon fibers. The High Shore hardness makes it stiffer than standard TPU filaments, while the fibers improve mechanical properties like tensile strength, flexural strength, and impact resistance. This material is ideal for parts that require flexibility along with improved structural integrity.

Storage:

Store in dry area, in a closed container away from moisture.

PRODUCT PARAMETERS

Parameter	Value
Filament diameter [mm]	1.75
Diameter tolerance [mm]	+/- 0,02
Oval tolerance [mm]	+/- 0,02

Spool dimensions [mm] (ø / height / hole ø)	200/57/52
Spool weight [g]	325
Spool material	Transparent PC
Weight with packaging [g]	1 550
Net weight [g]	1 000
Box dimensions [mm]	203/207/70

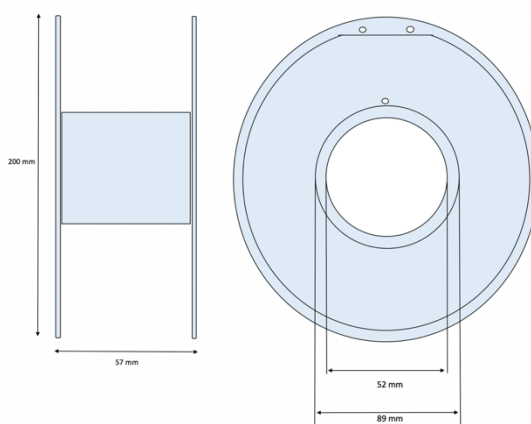

RECOMMENDED PRINTING PARAMETERS

Parameter	Value
Print temperature [°C]	230-270
Bed temperature [°C]	40-70
Cooling [%]	Moderate (30-50)
Closed chamber	Recommended
Chamber temperature [°C]	30-50
Printing Speed [mm/s]	30-90
Nozzle type	Hardened steel or ruby

PHYSICAL PARAMETERS OF THE MATERIAL

Parameter	Value	Unit	Test method
Density	1,37	g/cc	ISO 1183
Melt flow rate	4-7	g/10min	ISO 1133 220°C/10Kg
Vicat softening temp.	90-110	°C	ISO 306 VST/A/50 (50°C/h,10N)
Tensile modulus	350-500	MPa	ISO 527 1mm/min
Tensile strength	50-70	MPa	ISO 527 @Yield 50mm/min (2inch/min)
Elongation at break	150-200	%	ISO 527 @Break 50 mm/min (2inch/min)
Impact strength	15-20	KJ/m2	ISO 179 Charpy Notched @23°C (73°F)

The values above have been measured using standard test specimens made of non-colored material at room temperature. The figures should be considered as indicative values only. Actual properties of TPU FORCE parts can be affected by the printing parameters, design of the model, ambient conditions, application of the printout etc. It is essential that users test our products to determine whether they are suitable for their intended use.