

Product description:

UNIVERSAL NW is an industrial-grade, high-performance and FFF/FDM-optimized ABS based engineering filament. UNIVERSAL NW is the evolution of ABS into a warp-free filament with unsurpassed mechanical properties and is extremely suitable for 3D printing large scale and high precision engineering objects. UNIVERSAL NW is truly optimized as it has zero warping, a perfect interlayer adhesion and can be printed directly on a heated glass plate without any adhesives or tapes to be used.

Storage:

Store in dry area, in a closed container.

PRODUCT PARAMETERS

Parameter	Value
Filament diameter [mm]	1.75
Diameter tolerance [mm]	+/- 0,01
Oval tolerance [mm]	+/- 0,01

Spool dimensions [mm] (ϕ / height / hole ϕ)	200/57/52
Spool weight [g]	204
Spool material	Transparent SAN
Weight with packaging [g]	1 550
Net weight [g]	1 000
Box dimensions [mm]	203/207/70

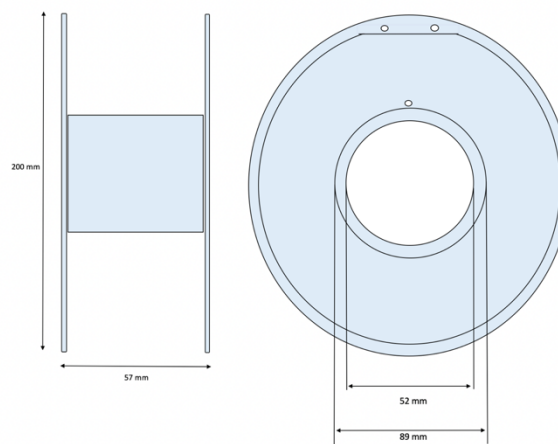

RECOMMENDED PRINTING PARAMETERS

Parameter	Value
Print temperature [°C]	240-270
Bed temperature [°C]	80-110
Cooling [%]	0-50
Closed chamber	Necessary
Chamber temperature [°C]	50-80
Printing Speed [mm/s]	30-60

PHYSICAL PARAMETERS OF THE MATERIAL

Parameter	Value	Unit	Test method
Density	1,10	g/cc	ISO 1183
Melt flow rate	41	g/10min	ISO 1133 260°C/5Kg
Vicat softening temp.	98	°C	ISO 306 VST/A/50 (50°C/h,10N)
Tensile modulus	2030	MPa	ISO 527 1mm/min
Tensile strength	43.6	MPa	ISO 527 @Yield 50mm/min (2inch/min)
Elongation at break	34	%	ISO 527 @Break 50 mm/min (2inch/min)
Impact strength	58	KJ/m2	ISO 179 Charpy Notched @23°C (73°F)

The values above have been measured using standard test specimens made of non-colored material at room temperature. The figures should be considered as indicative values only. Actual properties of UNIVERSAL NW parts can be affected by the printing parameters, design of the model, ambient conditions, application of the printout etc. It is essential that users test our products to determine whether they are suitable for their intended use.